

Anclaje de la fijación a la cubierta

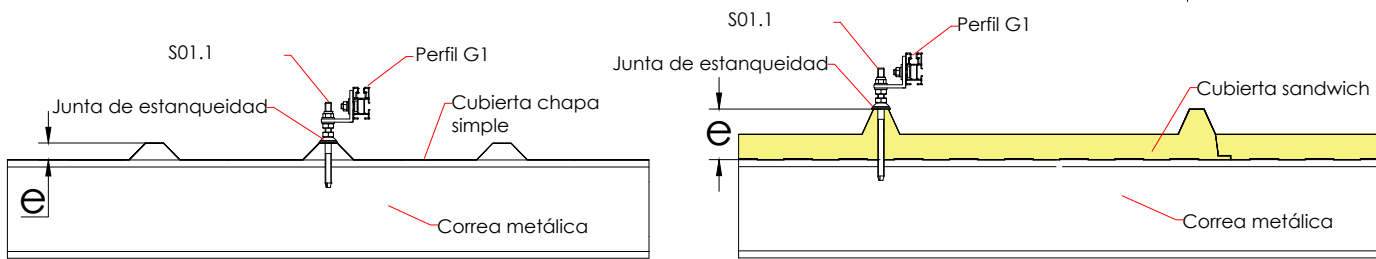

e máx. 90 mm
e mín. 40 mm

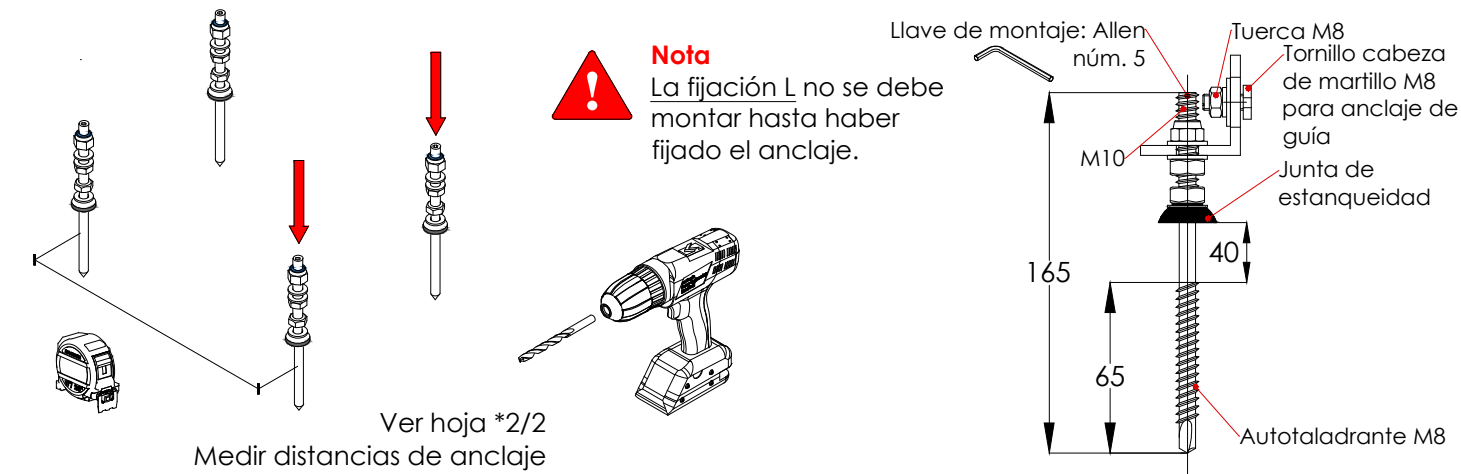

Colocación de los los perfiles guía sobre las fijaciones y unión entre perfiles

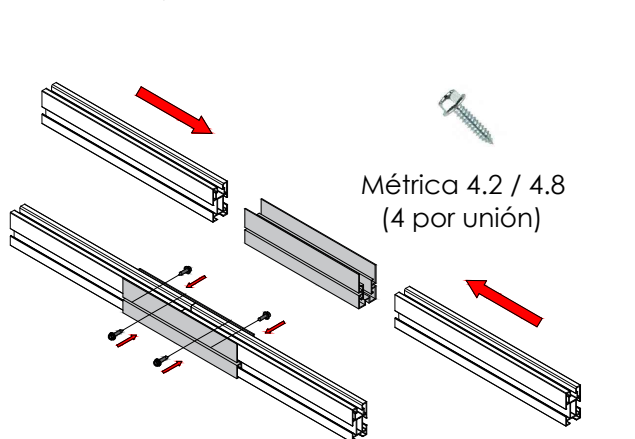
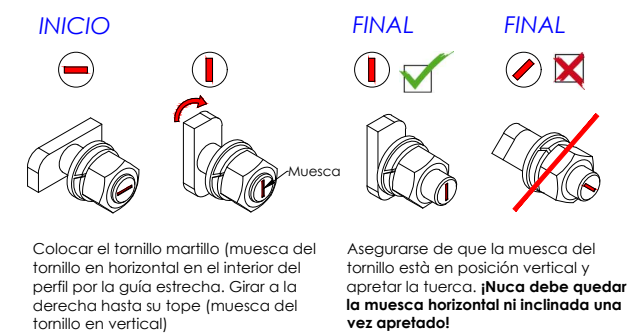

Introducir los perfiles dentro del carril del elemento de unión UG1 a través de las ranuras laterales. Y fijar la unión con los tornillos de bloqueo, siempre a la altura de la ranura lateral.

Soporte coplanar continuo atornillado a correas metálica Vertical. 01.1V

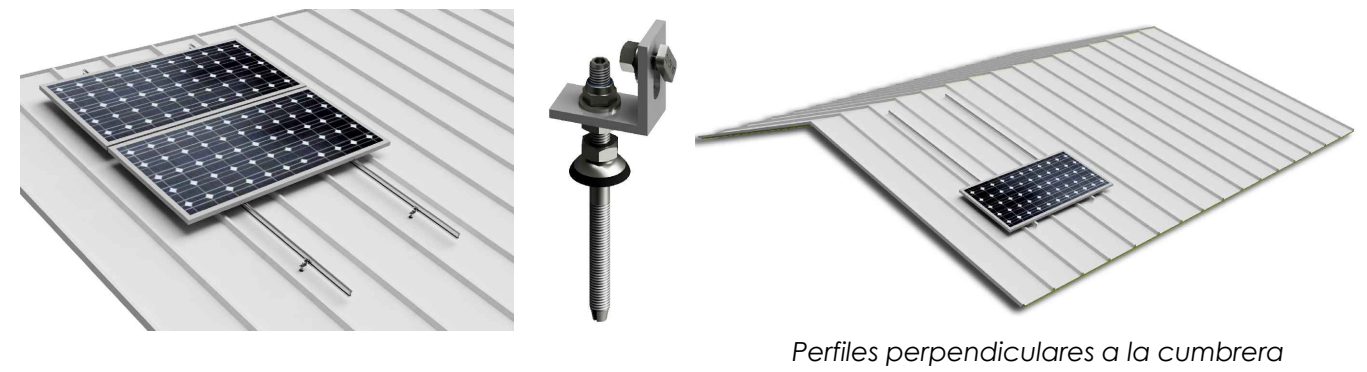

Perfiles perpendiculares a la cumbre

Ubicar los módulos sobre los perfiles

Distribuir los módulos para que su colocación sea simétrica a lo largo del soporte, dejando la misma distancia de sobrante en los extremos.

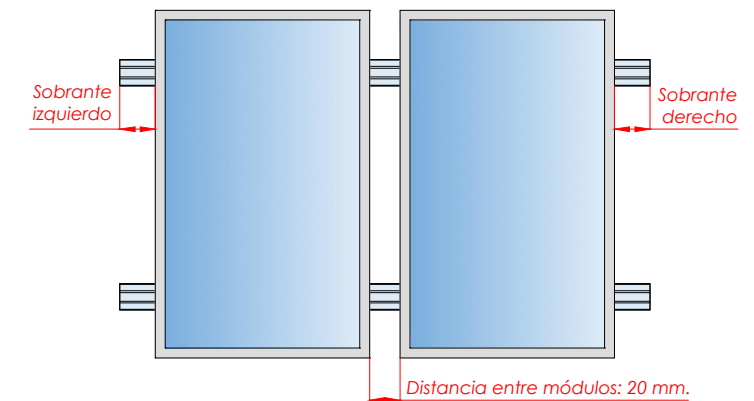

Dejar una separación entre módulos de 20 mm para poner el presor central que fijará los módulos al perfil.

Fijación de los módulos con los presores y colocación de las tapas G1

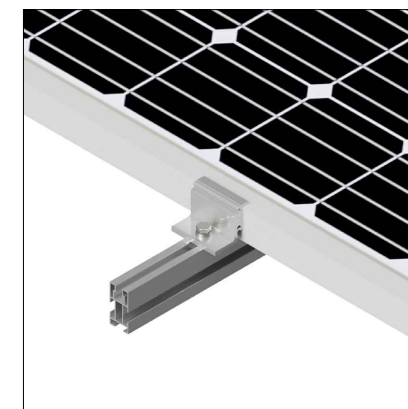
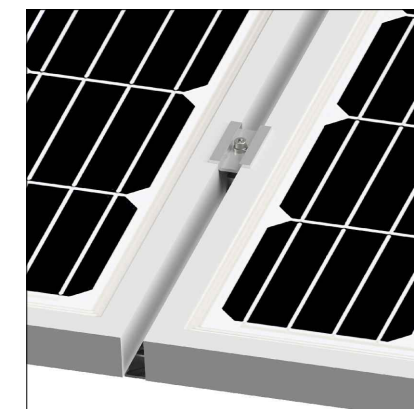

FIJACIÓN LATERAL

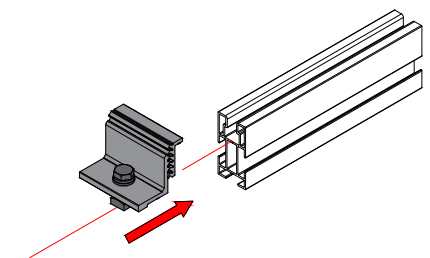

Tamaño máx.
2279x1150

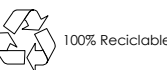
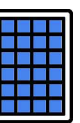

Marcado ES19/86524 CE

Nota:



- Comprobar el buen estado de la cubierta y la capacidad portante de la misma
- Comprobar la impermeabilidad de la fijación una vez colocada

Soporte coplanar continuo atornillado a correas metálica Vertical. 01.1V

01.1V

1

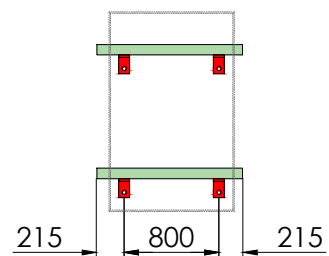

2

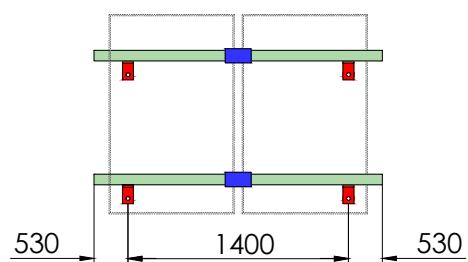

3

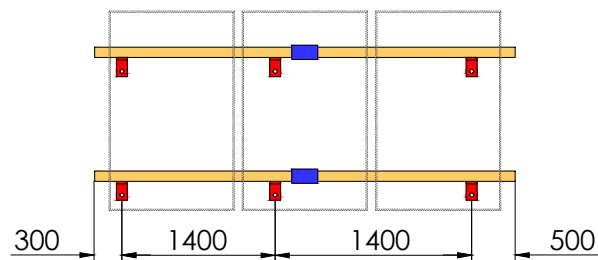

4

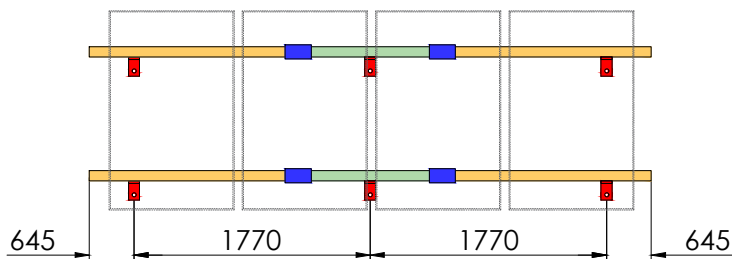

5

6*

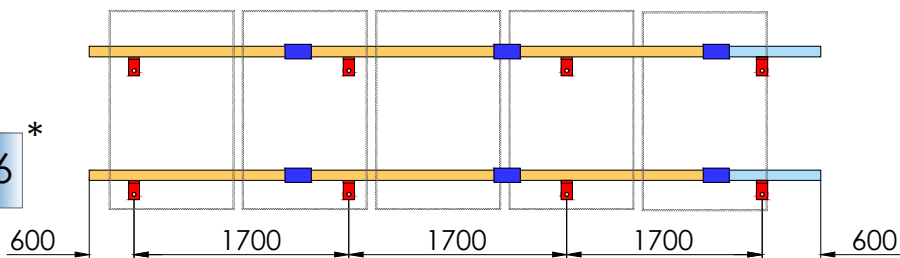

6

7*

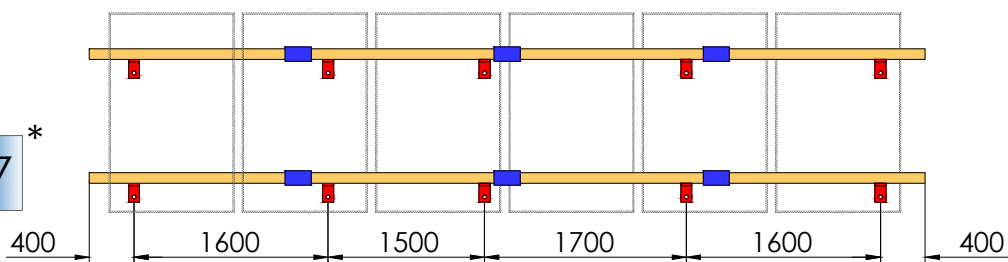

S01.1

Perfil G1 - 900

Perfil G1 - 1230

Perfil G1 - 1800

UG1

Par de apriete:

Tornillo Presor	7 Nm
Tornillo M8 Hexagonal	20 Nm
Tornillo M10 Hexagonal	40 Nm
Tornillo M4.2/4.8 Hexagonal	6 Nm



Distancia recomendada según fabricante de módulo fotovoltaico.

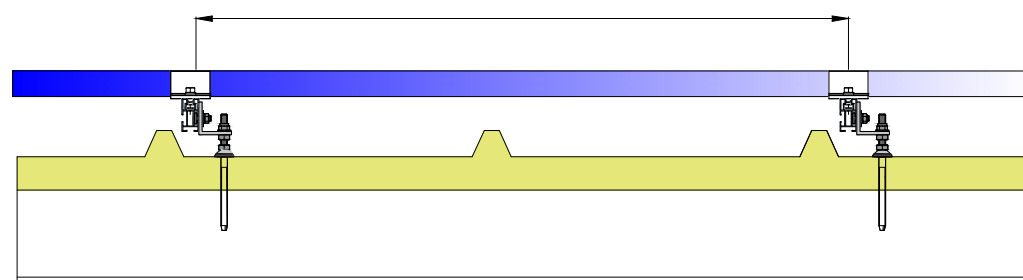

Revisar ficha técnica del módulo Tamaño máx. 2279x1150



S01.1



S10



S11



UG1



G1 - 900



G1 - 1230



G1 - 1800

	S01.1	S10	S11	UG1	G1 - 900	G1 - 1230	G1 - 1800
01.1V1	4	4	-	-	-	2	-
01.1V2	4	4	2	2	-	4	-
01.1V3	6	4	4	2	-	-	4
01.1V4	6	4	6	4	-	2	4

01.1V5 - Válido para 6 módulos de hasta 1000 mm de ancho (El kit incluye presores para el montaje de 6 módulos)

	S01.1	S10	S11	UG1	G1 - 900	G1 - 1230	G1 - 1800
01.1V5	8	4	8 + 2	6	2	-	6

01.1V6 - Válido para 7 módulos de hasta 1000 mm de ancho (El kit incluye presores para el montaje de 7 módulos)

	S01.1	S10	S11	UG1	G1 - 900	G1 - 1230	G1 - 1800
01.1V6	10	4	10 + 2	6	-	-	8

CARACTERÍSTICAS DEL MONTAJE



Marcado ES19/86524